

GENERAL

The RCM Series mag is a very compact electromagnetic flow sensor and transmitter designed for low flow measurement. These non-intrusive sensors are suitable for conductive liquid media, such as aqueous solutions, corrosive fluids, water based paints and slurries.

OPERATION

When a conductive liquid is moved through the magnetic field in the flow sensor, a voltage is induced in the conductive liquid. Two diametrically opposed electrodes pick up the induced voltage. The amplitude of the induced voltage is strictly proportional to the velocity and correspondingly to the flow rate of the liquid in the flow sensor. The induced voltage is measured and processed digitally to produce an accurate flow output.

APPLICATIONS

Because of the inherent advantages of this technology, the RCM can be used on many industrial flow applications including corrosive, and/or viscous low flows. Industries include research and development, water and waste water, chemical, pulp and paper. Anywhere compact low flow measurement is required.



FEATURES

- Ceramic flow tube
- Platinum electrodes
- Keypad programming
- 4 line display
- Fast response time
- Enhanced low flow accuracy
- Full scale flow down to 30 cc/min
- Integral and Remote Electronics
- 3-A approved models
- CIP capable
- 316 sst, PVDF, and other end connection materials available
- Standard and special end connections available.

MODEL	TUBE SIZE	Smallest full scale flow range	Highest full scale flow range
RCM 40	1/24" (1.2 mm)	0-0.008 GPM (30 cc/min)	0-0.25 GPM (946 cc/min)
RCM 125	1/8" (3.2 mm)	0-0.025 GPM (100 cc/min)	0-1.5 GPM (5677 cc/min)
RCM 250	1/4" (6 mm)	0-0.2 GPM (0.75 l/min)	0-6.0 GPM (22.7 l/min)
RCM 375	3/8" (10 mm)	0-0.4 GPM (1.5 l/min)	0-12.0 GPM (45.4 l/min)

Model Number

Model	End Connections		Flow Tube	End Connection Material		Gasket Material		Electronics		Ratings		
RCM40	1N	1/8" NPT	CP	Ceramic/Platinum	36	316SST	E	EPDM	R	Remote	GP	None
RCM125	2N	1/4" NPT			KY	PVDF (Kynar)	B	BUNA N	I	Intergal		
RCM250	3N	3/8" NPT			HC	HAST-C	V	VITON				
RCM375	TC	1/2" TRI-CLAMP					T	TEFLON				
	SP	Special										

Example: RCM125-2N-CP-36-E-R-GP



Remote Electronic

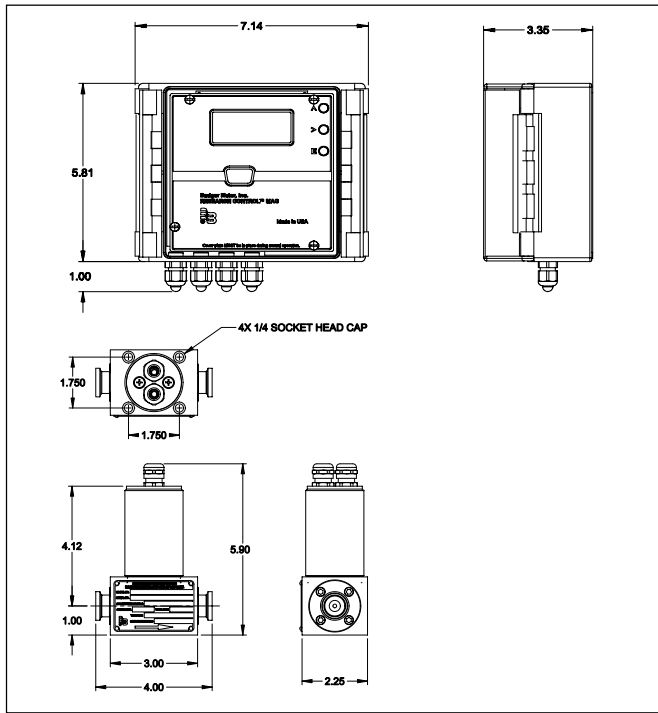

Integral Electronic

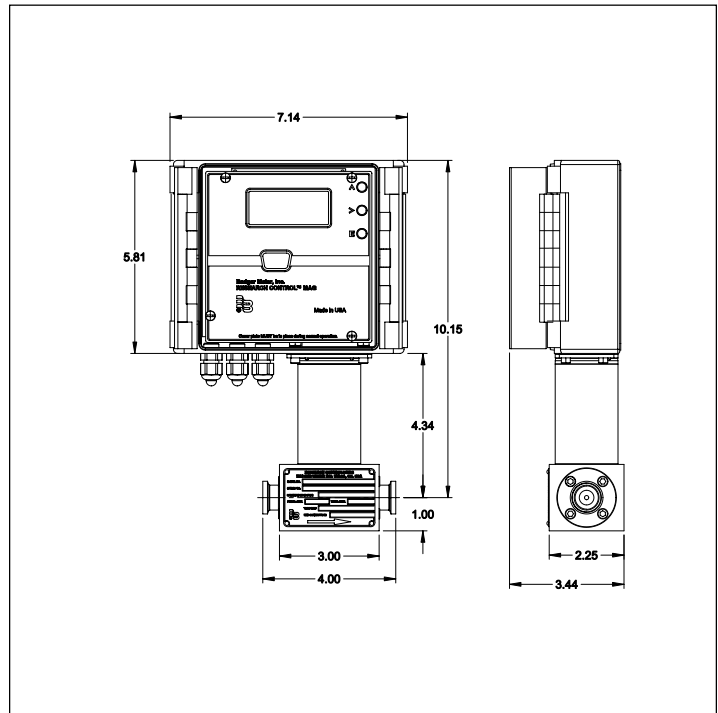

RCM Flow Sensor Technical Specification

Type	Pulsed D.C.
Conductivity	Minimum 0.5 $\mu\text{S}/\text{cm}$ (0.5 $\mu\text{mho}/\text{cm}$)
Liner	Ceramic
Electrodes	Platinum
Seal Material	EPDM standard - Buna N, Viton or Teflon optional
End Connections	316 Stainless standard, Kynar or Alloy-C optional
Housing	AISI 316 Stainless
Rating	NEMA 4x (IP67)

RCM 2000 Transmitter Technical Specification

Electronics Enclosure

Polycarbonate IP66/NEMA 4X
Enclosure 6"H x 6"W x 3.5"D

Electrical

AC Power

85-240 vac 50/60Hz (fuse rating 0.1A)

10watt power dissipation

DC Power

24VDC @ 300mA continuous power dissipation, < 100mA in power save mode

Optional 9-36 VDC @ 300mA continuous power dissipation, <50mA in power save mode.

Temperature Electronics:

-4F to 160F (-20C to 70C) Std

95% Humidity

-40F to 160F (-40C to 70C) Optional

Display

The 4line x 16char backlit LCD display indicates:

- Flow
- Velocity
- System and set point status
- 8 digit totalizer

Accuracy

+/- 0.5% of reading for flow velocities > 0.8 ft/s (0.25 m/s)

+/- 0.004 ft/s (0.00125 m/s) for flow velocities < 0.8 ft/s (0.25 m/s)

Connection Options

1/8" NPT female

1/4" NPT female

3/8" NPT female 1/2" Sanitary Tri Clamp

Menus

Menus allow the user to make changes on the fly or load in configuration files through the serial port. Level contrast adjustment is available through the menu. Backlighting can be disabled to conserve power.

Analog Outputs

A single 4-20mA output indicating flow is optically isolated and capable of driving over 800 ohms of loop resistance. The output is monitored to detect open circuit and has RFI and surge protection built in.

Digital Outputs

Two optically-isolated(open collector or CMOS,TTL) that can be programmed for frequency or set point.

Digital Input

One optically-isolated(open collector or contact closure) that can be programmed for positive zero return.

Serial Output

A single non-isolated RS-232 serial port intended for local serial access for downloading data, programming the meter, or viewing status information.

Limits

Max. Distance between Sensor and Converter	300 ft (100m)
Max. Media Temperature	220°F (105°C)
Max. CIP Stream Temperature	265°F (130°C)
Max. Media Pressure	360 psig (25 bar)
Max. Media Velocity	40 ft/s (12 m/s)



Please see our website at
www.badgermeter.com
for specific contacts.

Due to continuous research, product improvements and enhancements, Badger Meter reserves the right to change product or system specifications without notice, except to the extent an outstanding bid obligation exists.



BadgerMeter, Inc.

P.O. Box 581390, Tulsa, Oklahoma 74158
(918) 836-8411 / Fax: (918) 832-9962

www.badgermeter.com